

**Overview projekt of sailing  
catamaran SerShu  
(LOA - 9,5 m.)**

**Specification of sailing catamaran SerShu**

<b>L.O.A. max long</b>	.....	<b>9.55 m</b>
<b>L.W.L. long on the waterline</b>	.....	<b>9.55 m</b>
<b>B max width total</b>	.....	<b>5.82 m</b>
<b>design of sediment</b>	.....	<b>0.830 m</b>
<b>Displacement max</b>	.....	<b>4200 kg</b>
<b>Weight</b>	.....	<b>3200 kg</b>
<b>LOA / LWL</b>	.....	<b>9:1</b>
<b>Loading capacity</b>	.....	<b>1000 kg</b>
<b>4 cabins</b>	.....	<b>for 6 guests</b>
<b>Passanger capacity</b>	.....	<b>12 guests</b>
<b>Water tanks</b>	.....	<b>140 L</b>
<b>Fiel tanks</b>	.....	<b>110 L</b>
<b>Engine - outboard</b>	.....	<b>2 no 15 hp</b>
<b>Sail Plan</b>	.....	<b>Mainsail - 30m2, Genoa - 20 m2, Gennaker - 50 m2</b>

30 m2

20 m2

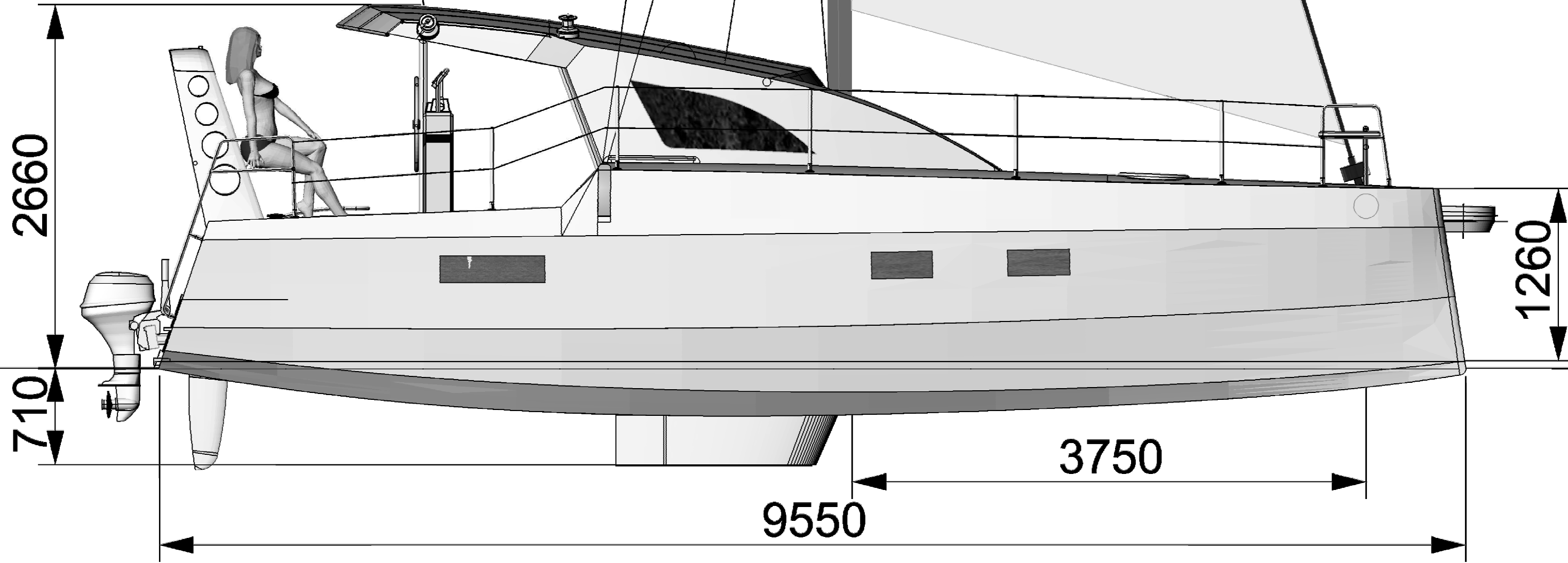

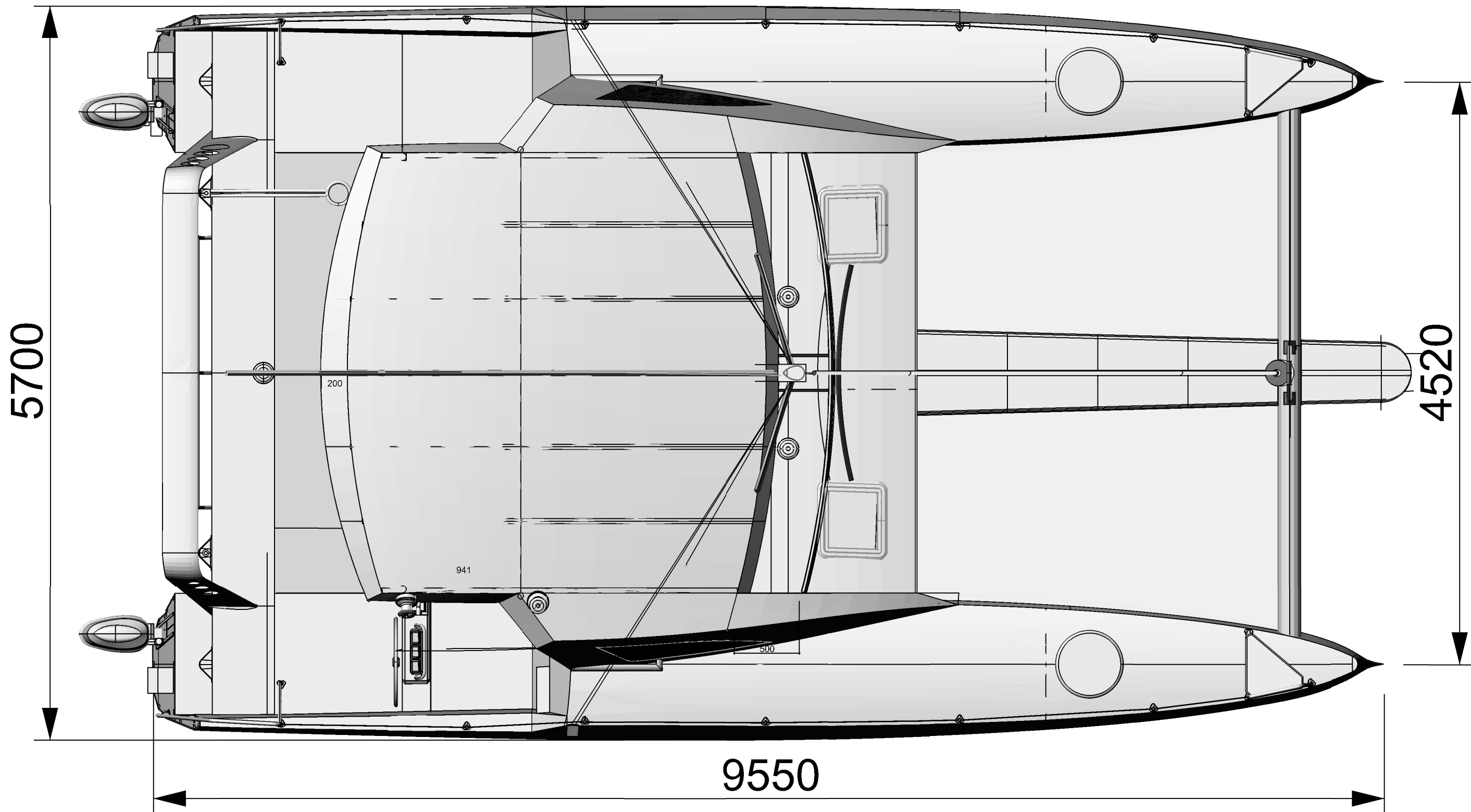

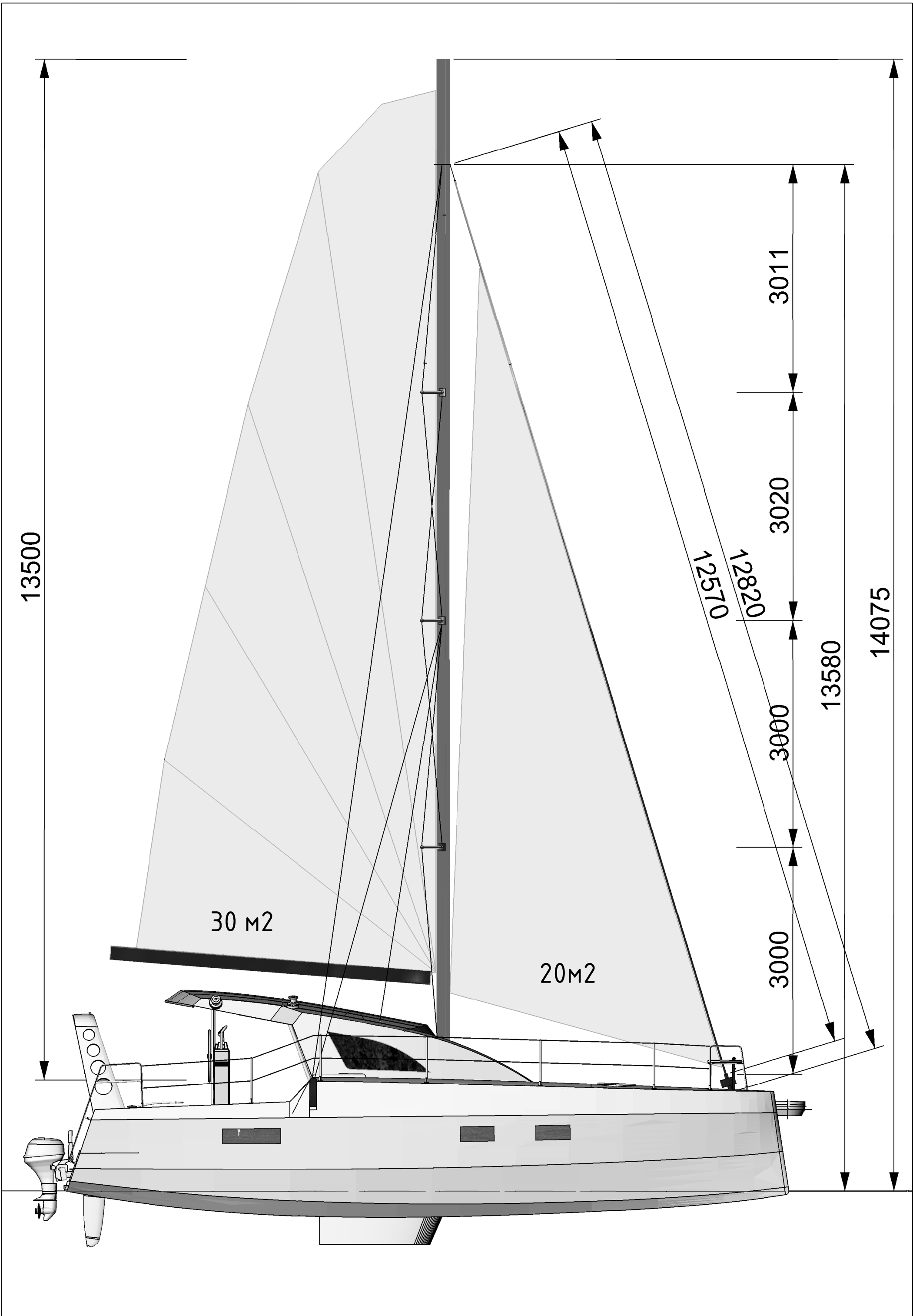

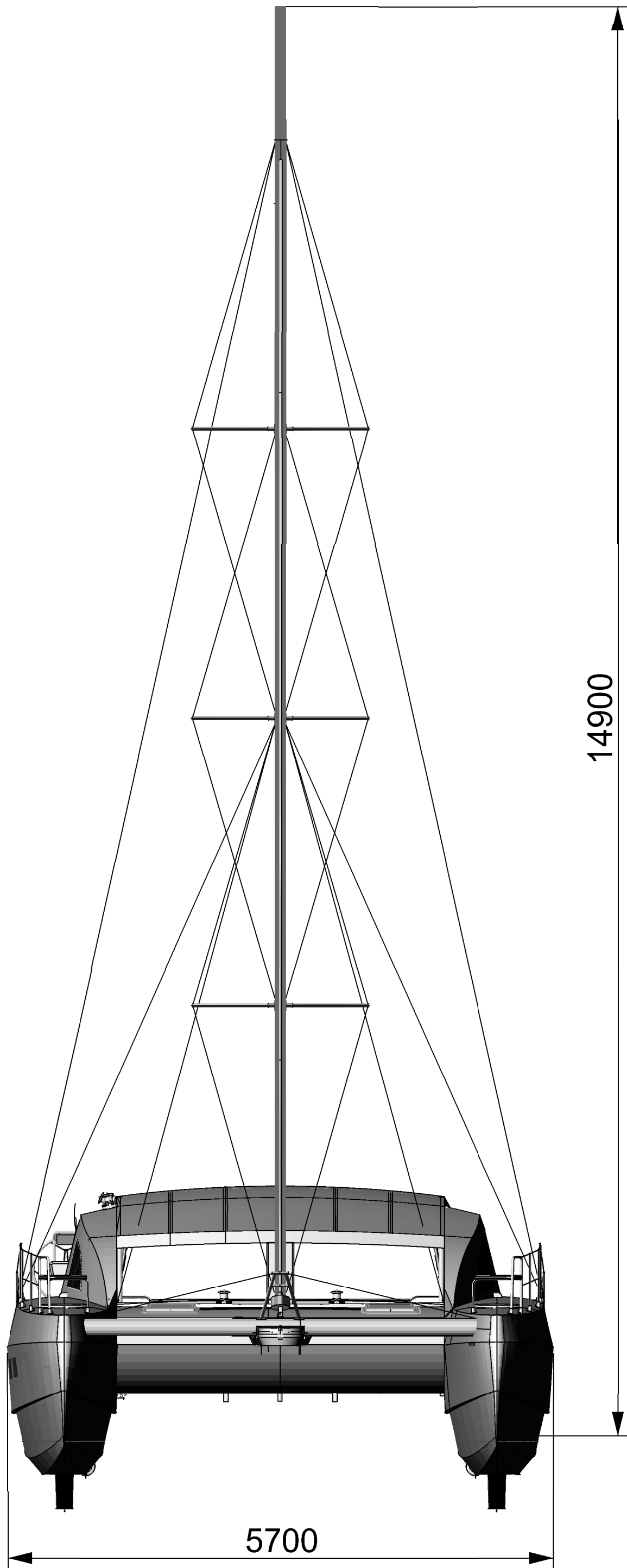

5700

14900

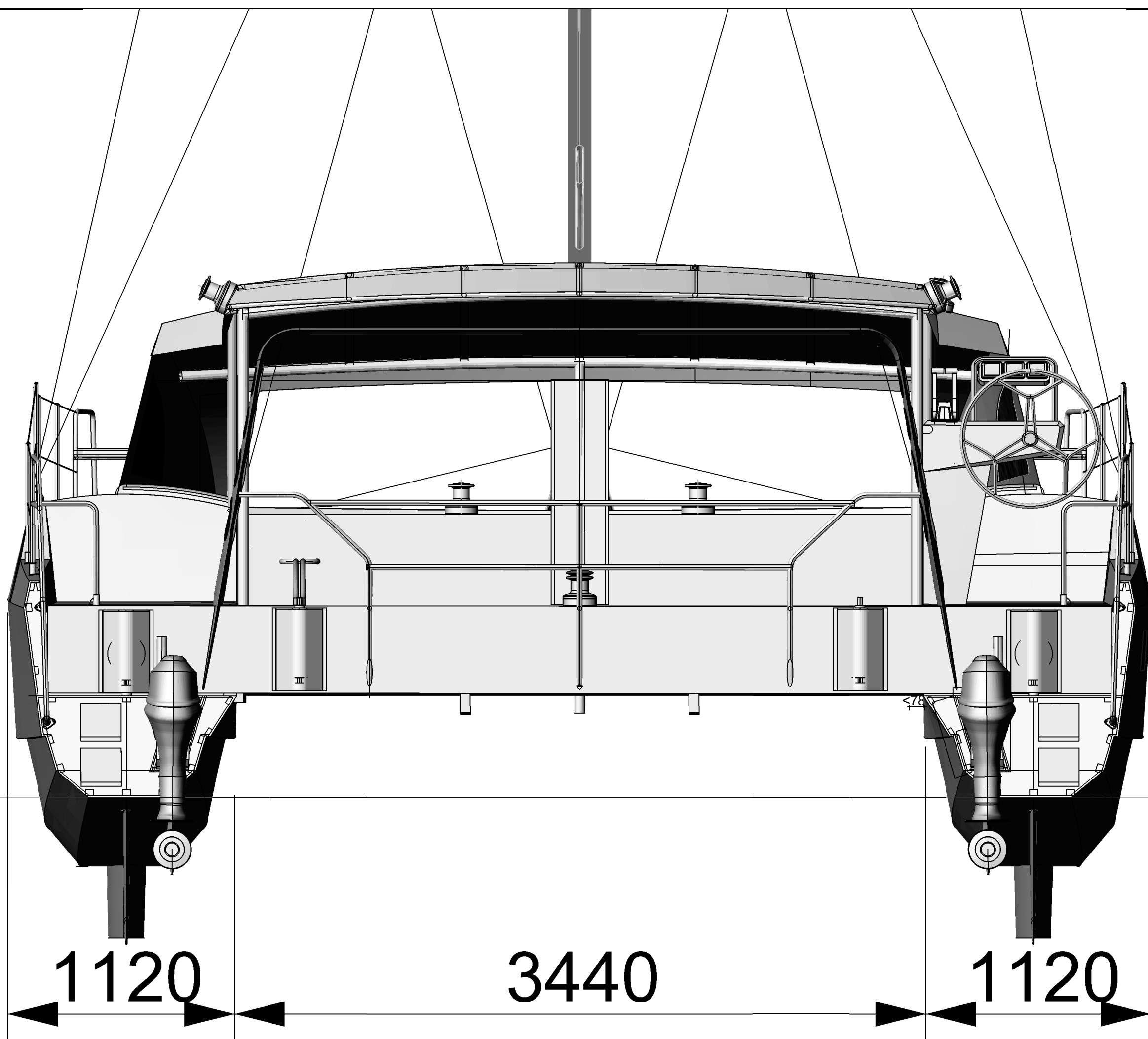

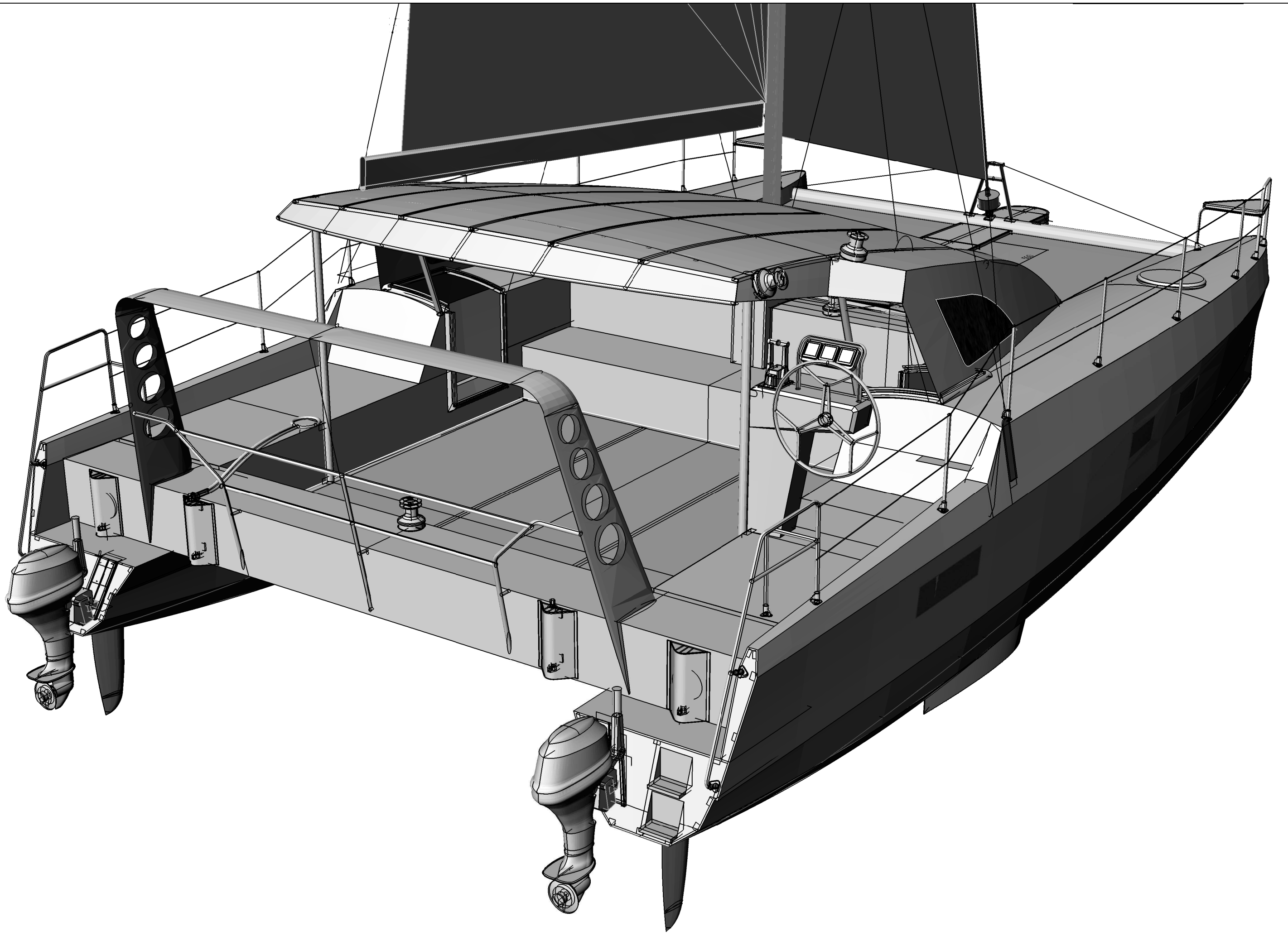

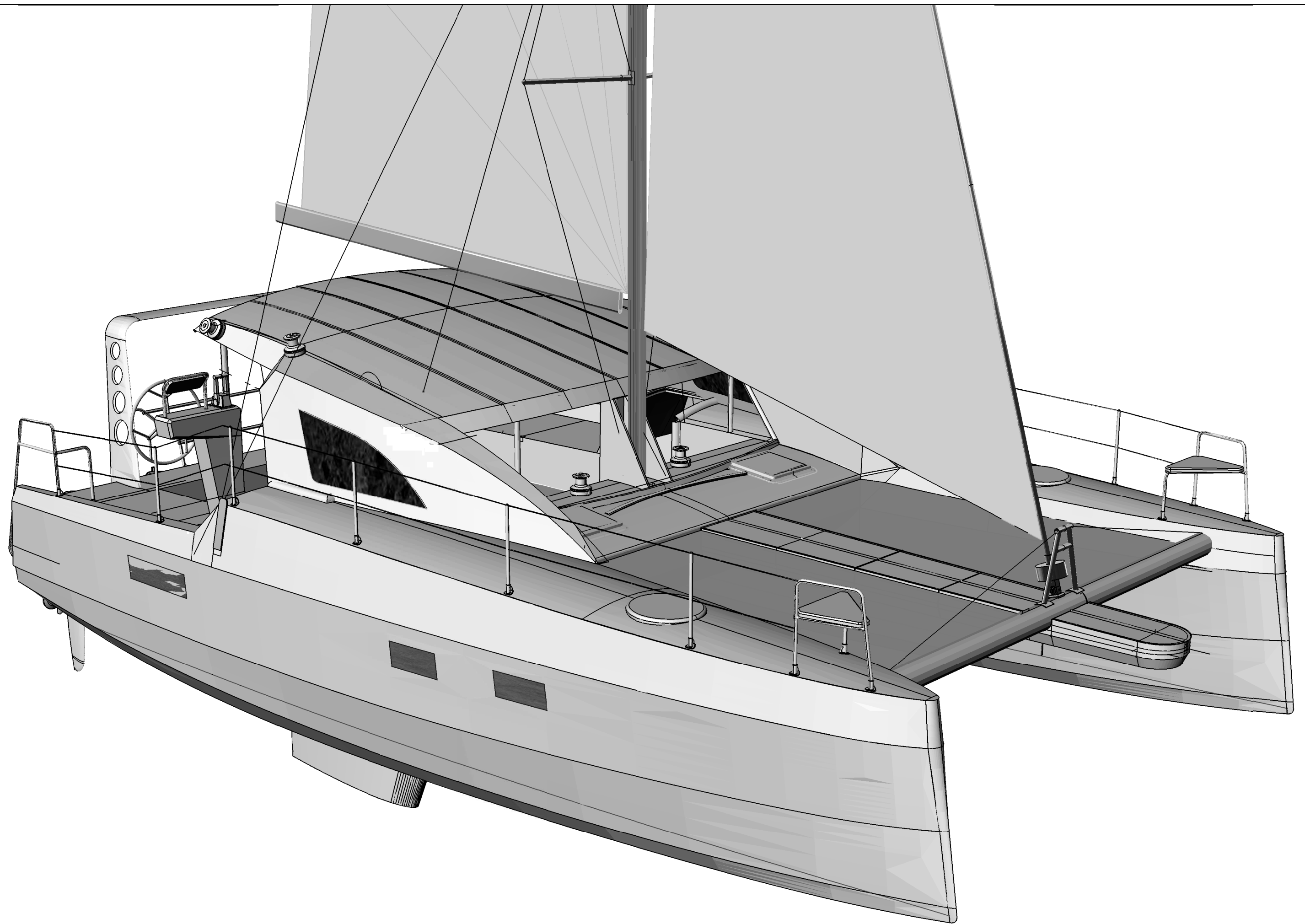



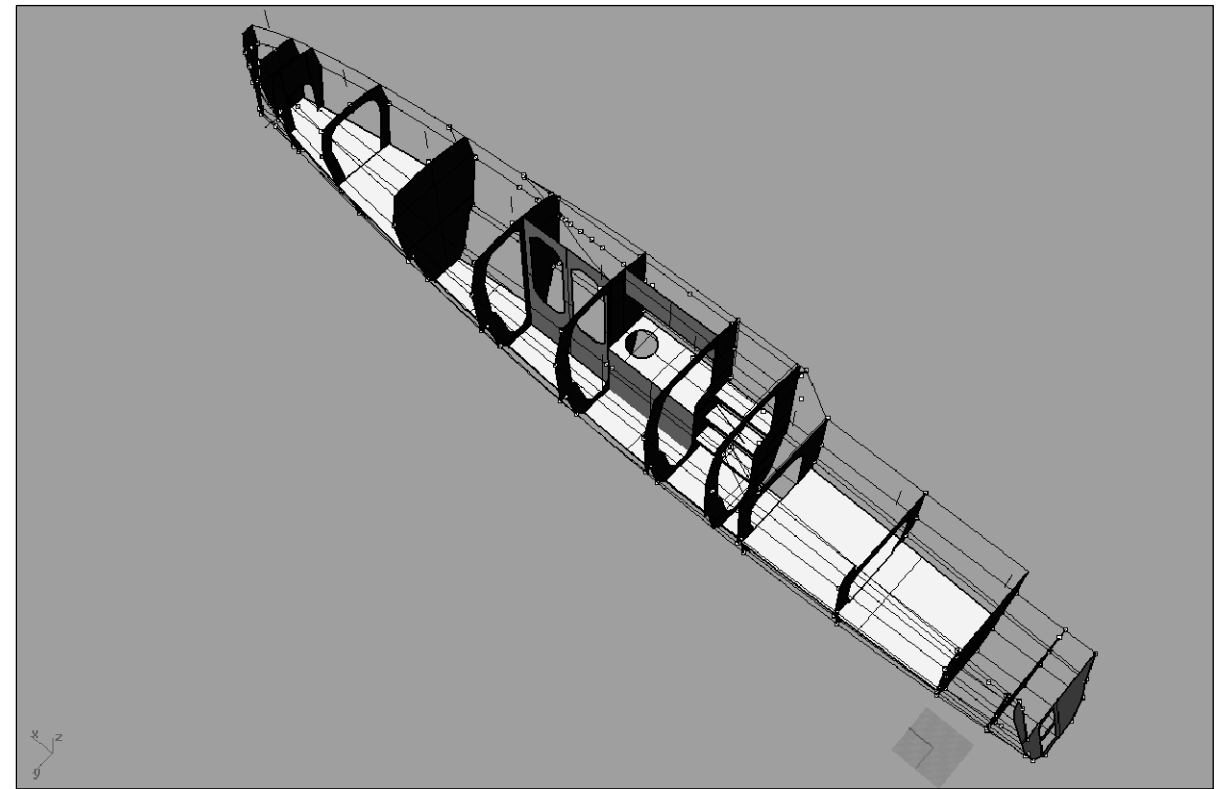
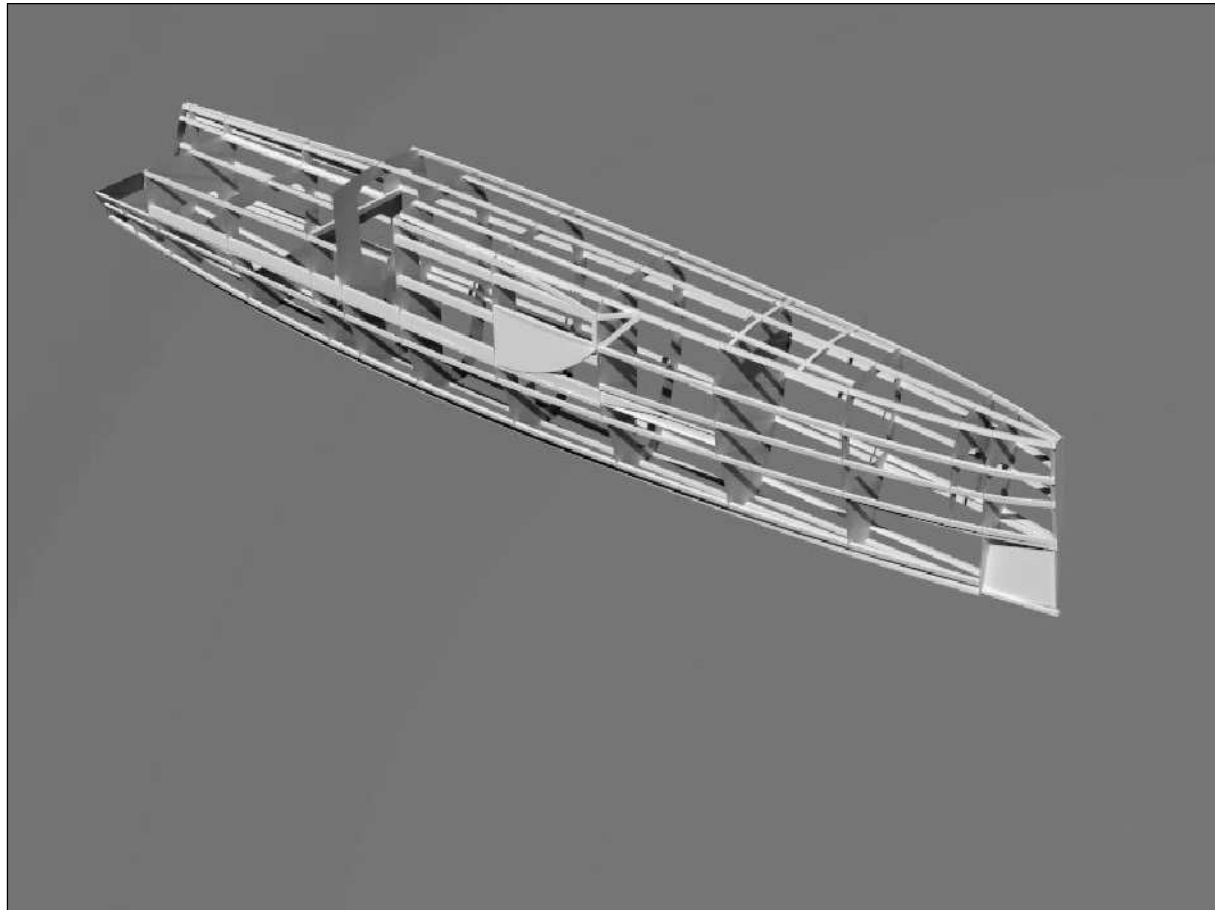
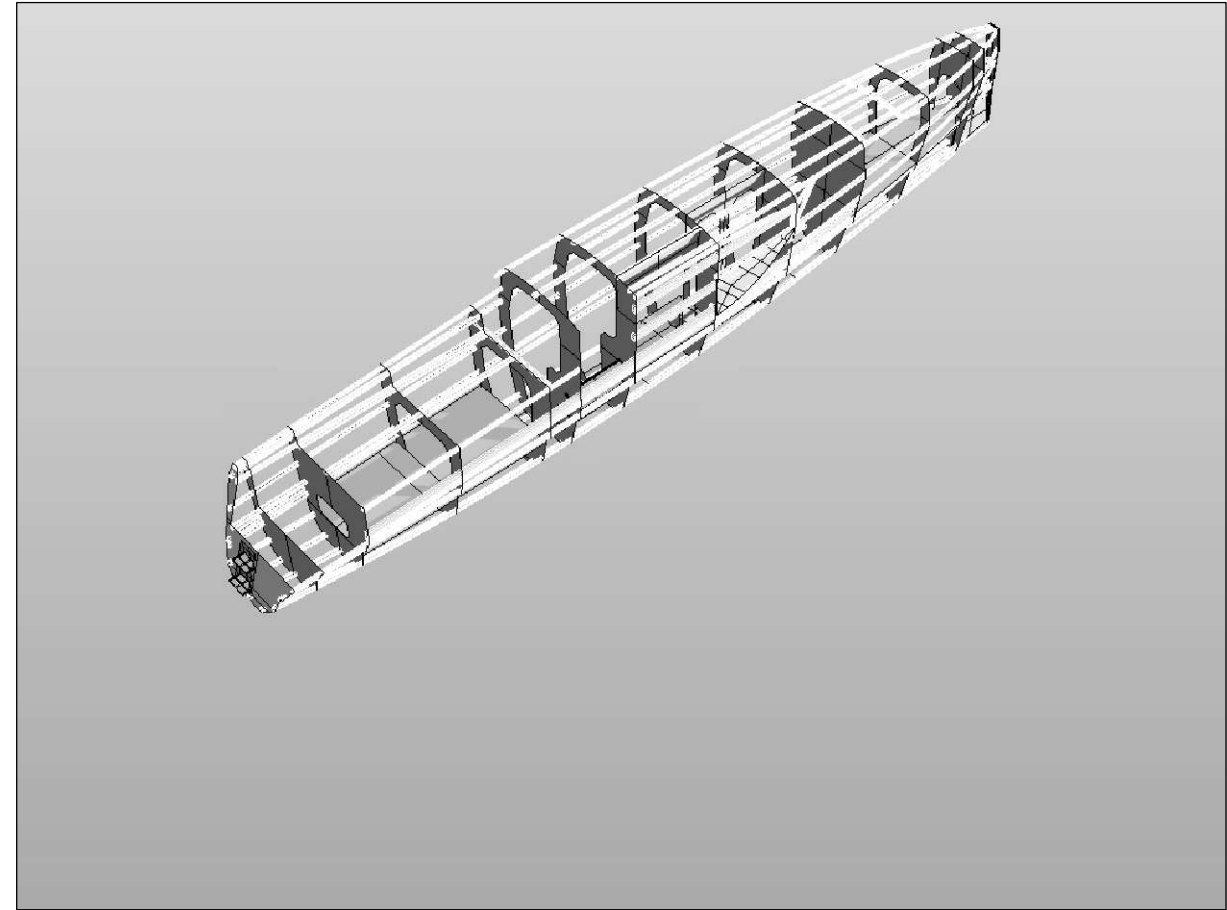
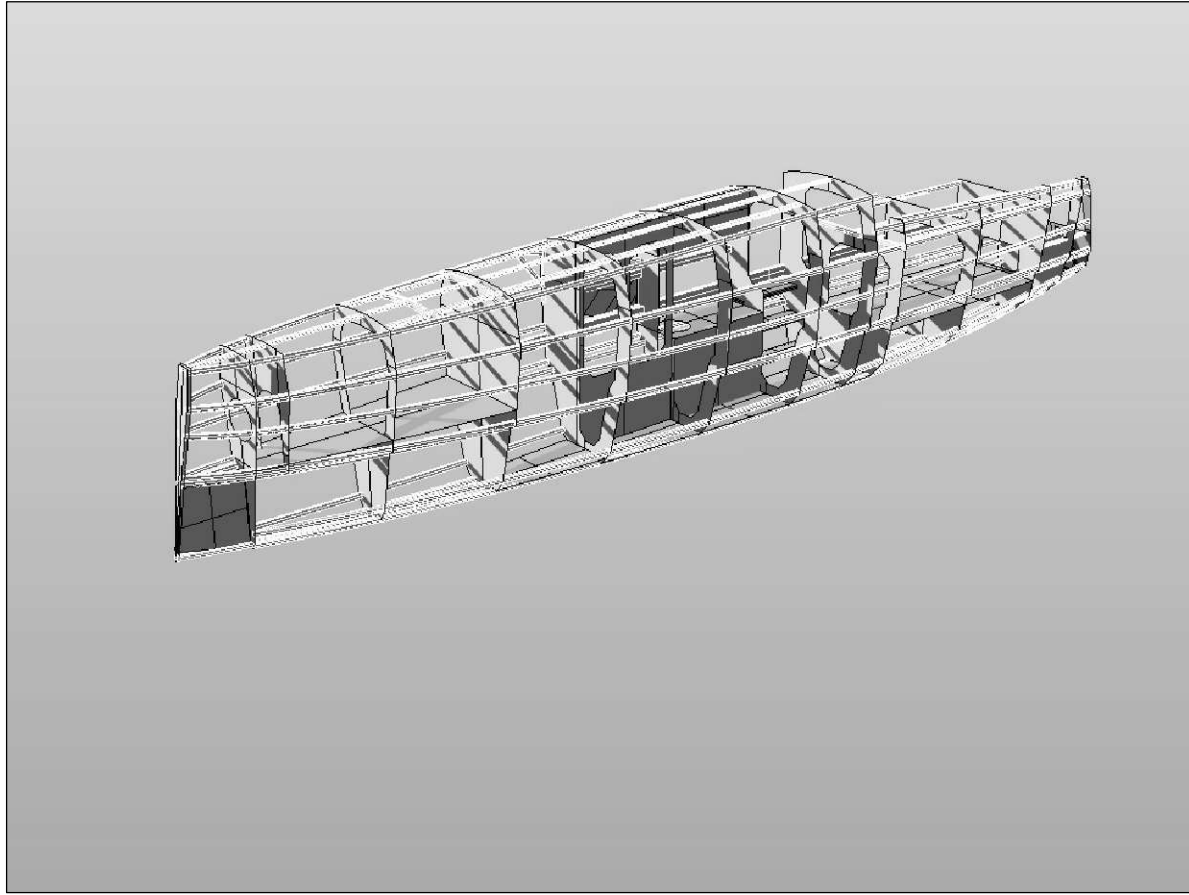

**All parts of hull are made from plywood and wood. Externally hull covered by epoxy resin with embedded fiberglass.**